

6.12 MASTER BATH VANITY PLAN
 5 Scale: 1/2" = 1'

Name:		
Drawn By:	Drawing Number: 1	Revision:
Date:	Scale: 1/2" = 1'	

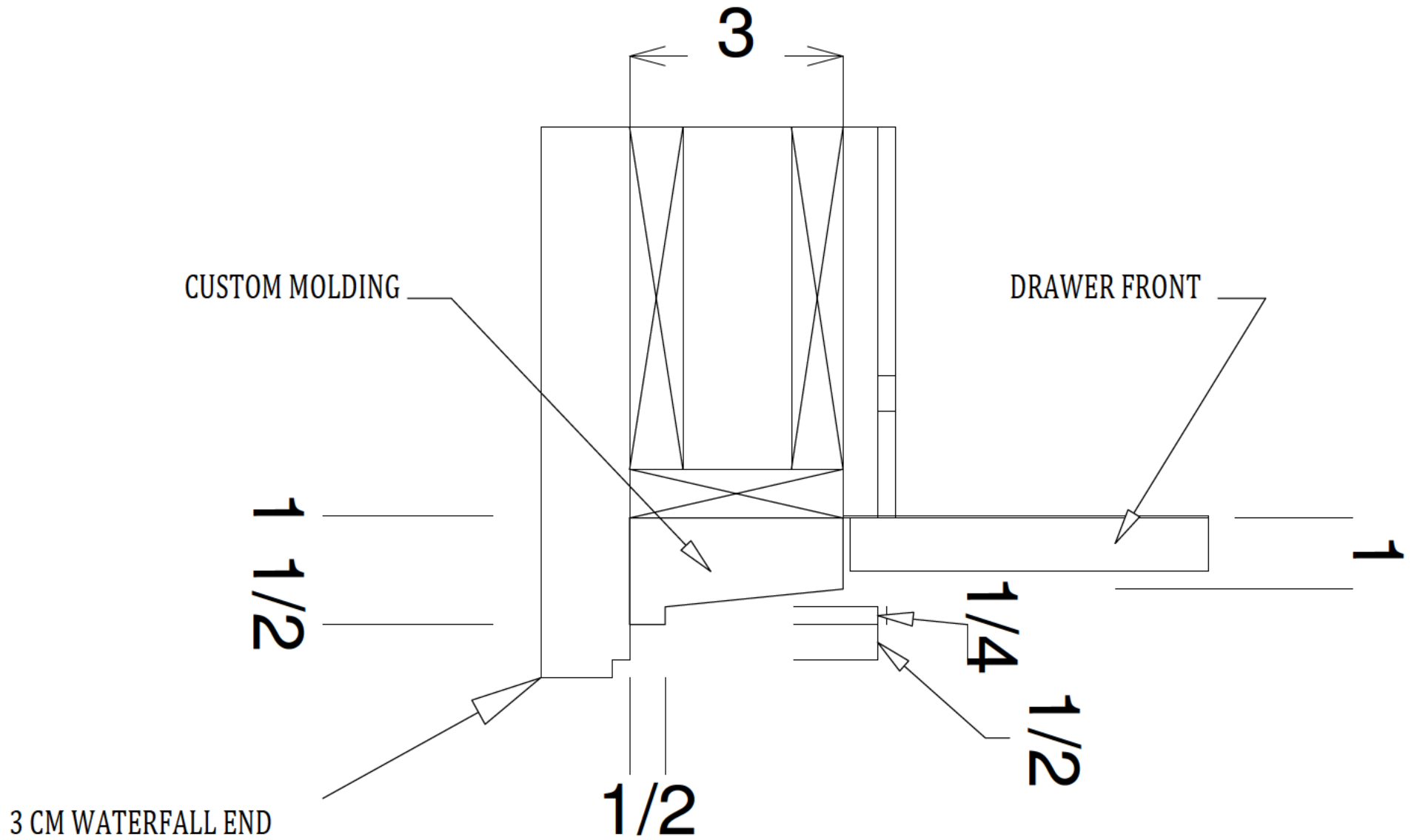

7.15
2

DETAIL "A" PLAN
Scale: 1 : 2

Name:		
Drawn By:	Drawing Number: 2	Revision:
Date:	Scale: 1:2	

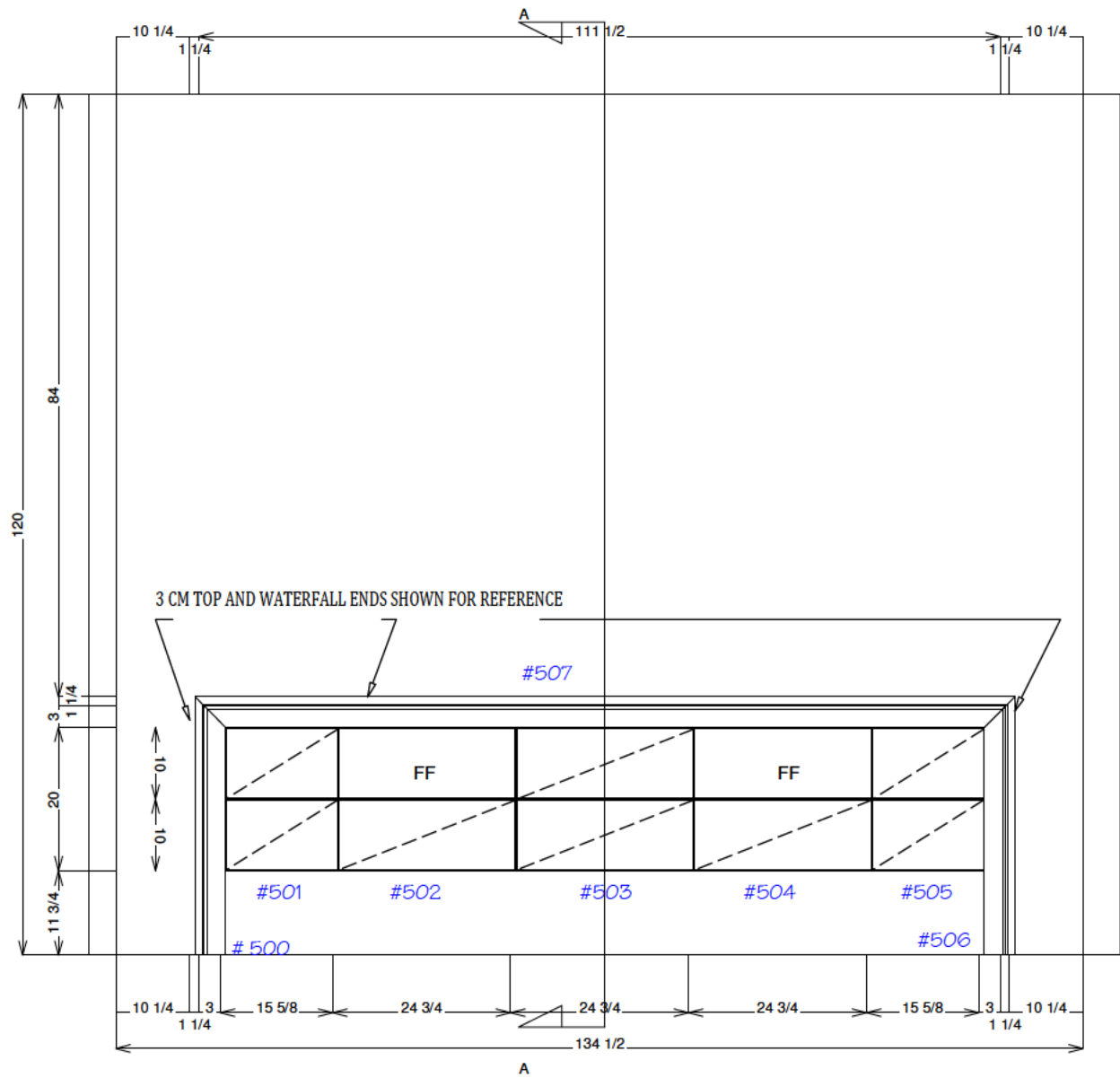

6.12 MASTER BATH VANITY ELEVATION
 Scale: 1/2" = 1'

Name:		
Drawn By:	Drawing Number: 3	Revision:
Date:	Scale: 1/2" = 1'	

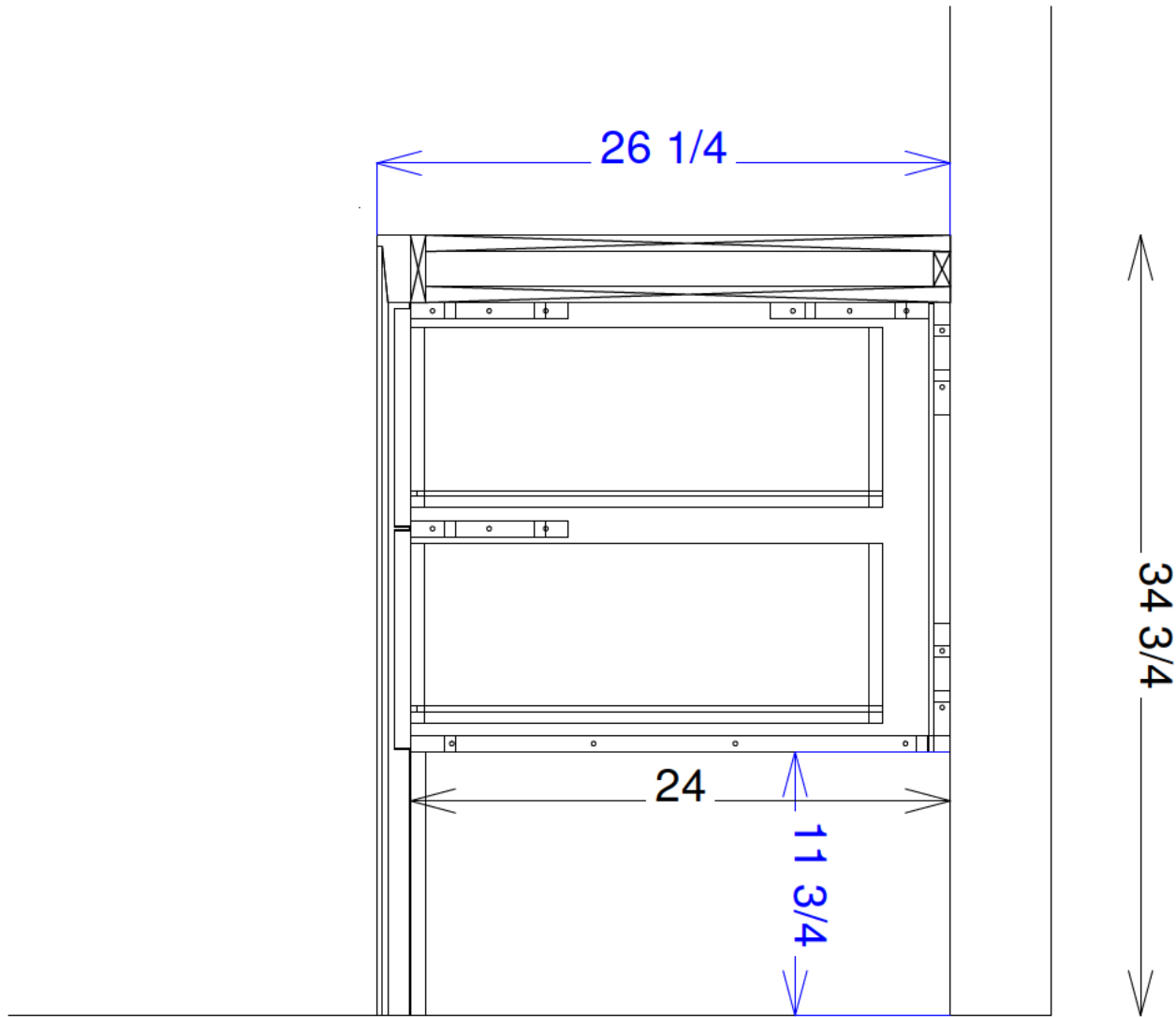

6.12
4.1A

MASTER BATH VANITY SECTION

Scale: 1 1/2" = 1'

A

Name:		
Drawn By:	Drawing Number: 4	Revision:
Date:	Scale: 1 1/2" = 1'	

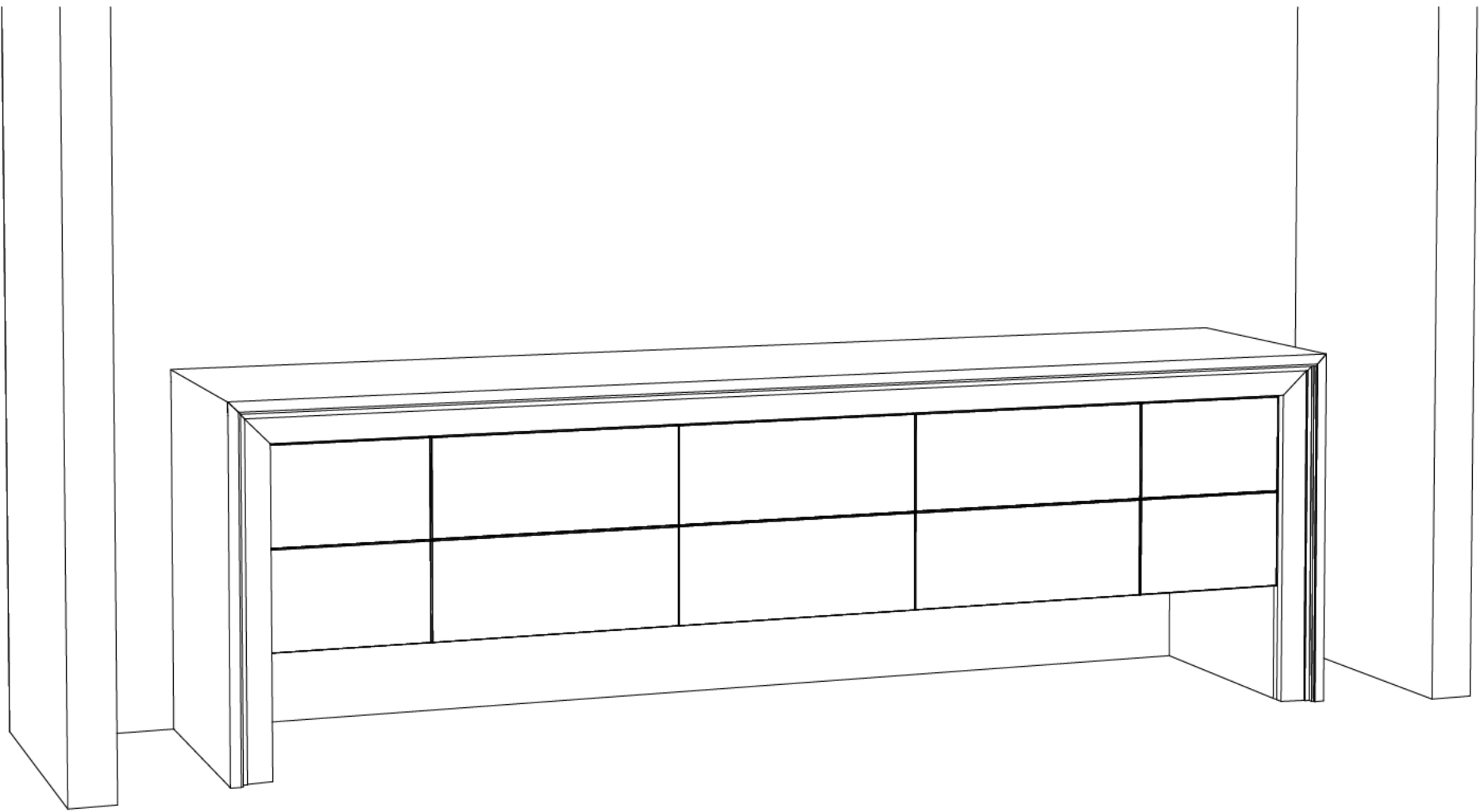

6.12
4.1

MASTER BATH VANITY PERSPECTIVE

Scale: 2" = 1'

Name:		
Drawn By:	Drawing Number: 5	Revision:
Date:	Scale: 2" = 1'	

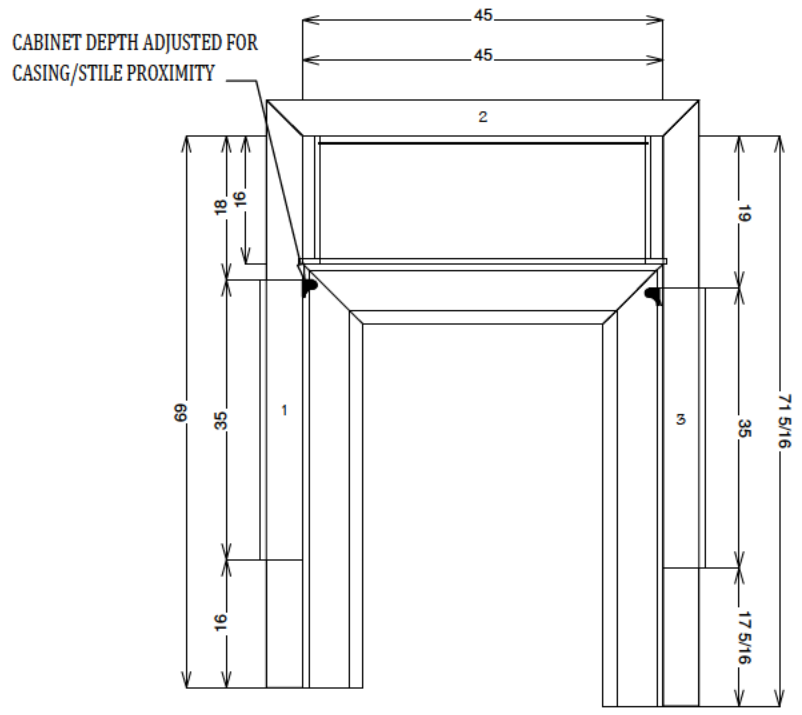

6.10
4

MASTER VESTIBULE PLAN

Scale: 1/2" = 1'

Name:		
Drawn By:	Drawing Number: 6	Revision:
Date:	Scale: 1/2" = 1'	

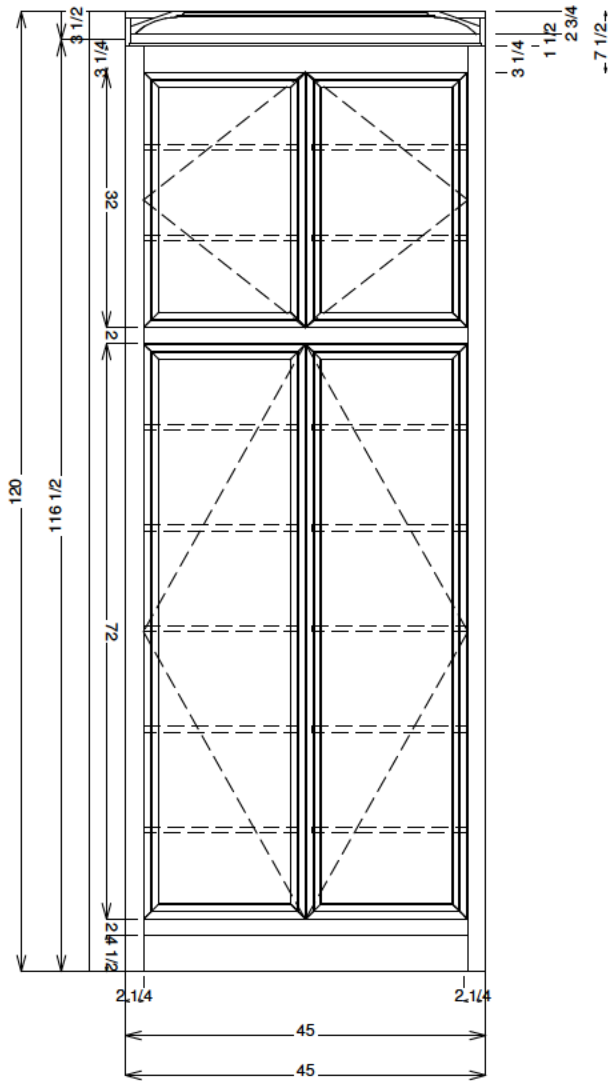

6.10
3 MASTER VESTIBULE ELEVATION
Scale: 1/2" = 1'

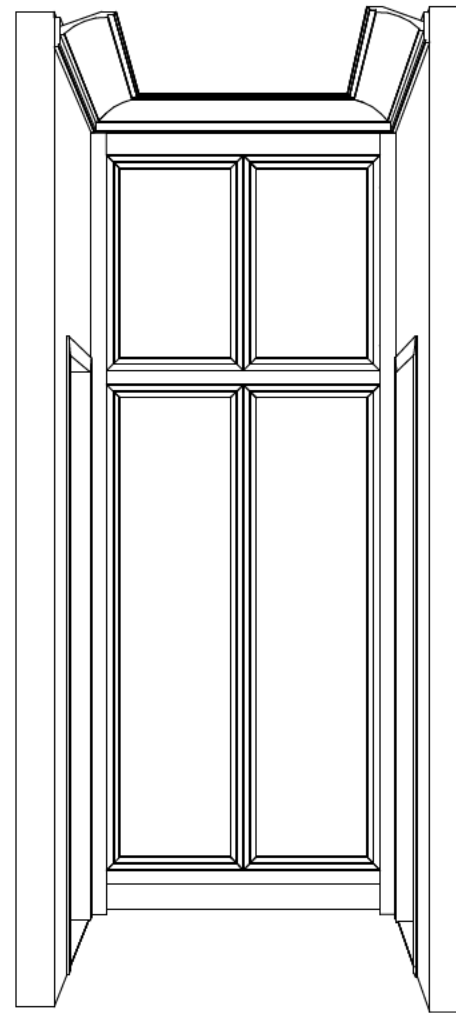

6.10
3.1 MASTER VESTIBULE PERSPECTIVE
Scale: 1" = 1'

Name:		
Drawn By:	Drawing Number: 7	Revision:
Date:	Scale:	

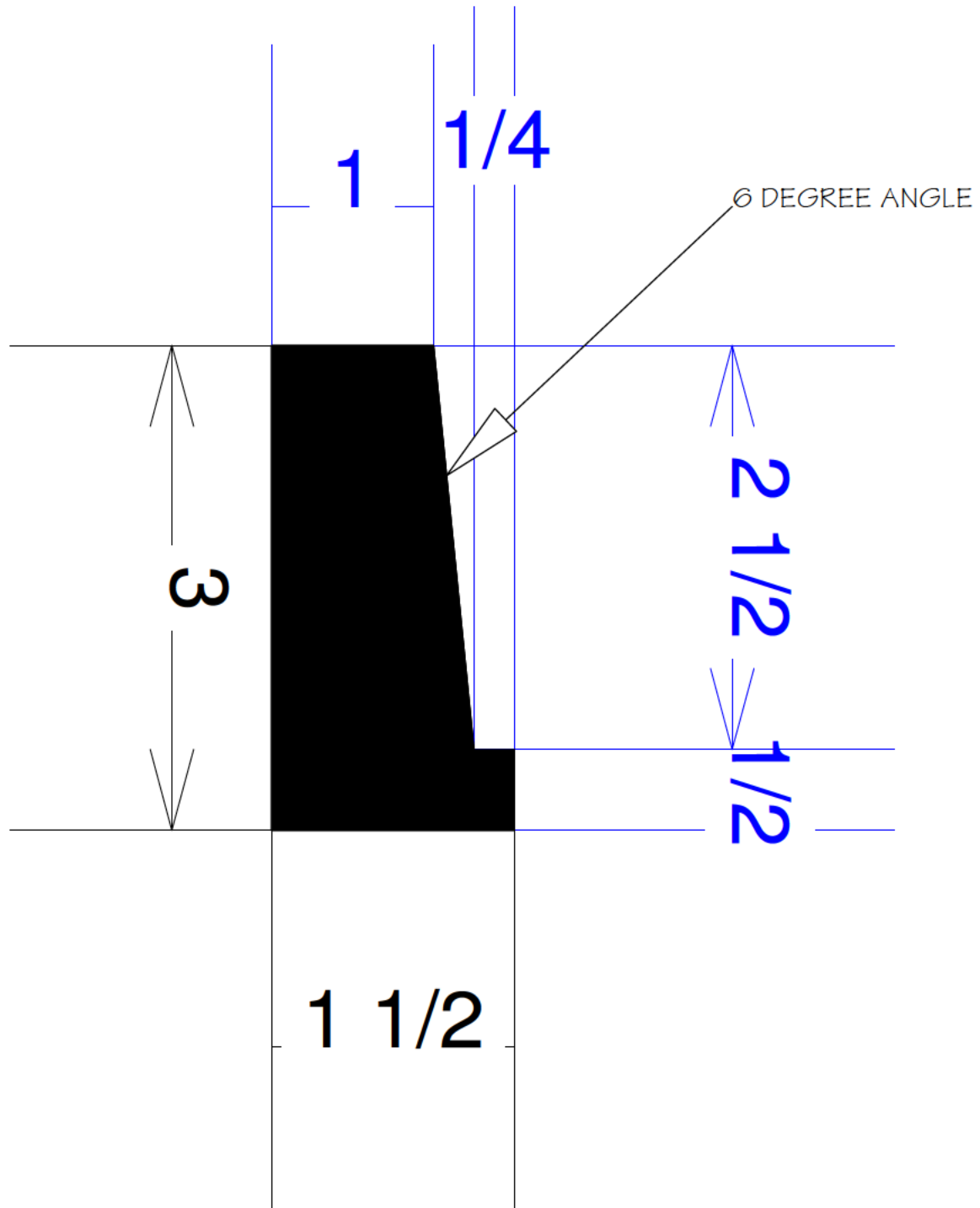

MASTER VANITY MOLDING

Name:		
Drawn By:	Drawing Number: 8	Revision:
Date:	Scale:	

Frame

1	2	40 1/2	Bottom Rail	3/4 Solid Maple
1	2 3/4	117	Right Stile	3/4 Solid Maple
1	4	40 1/2	Top Rail	3/4 Solid Maple
1	2 3/4	117	Left Stile	3/4 Solid Maple
1	2	40 1/2	Mid Rail	3/4 Solid Maple

Assembly #600 - Std Tall

45 x 116 1/2 x 16 (1)

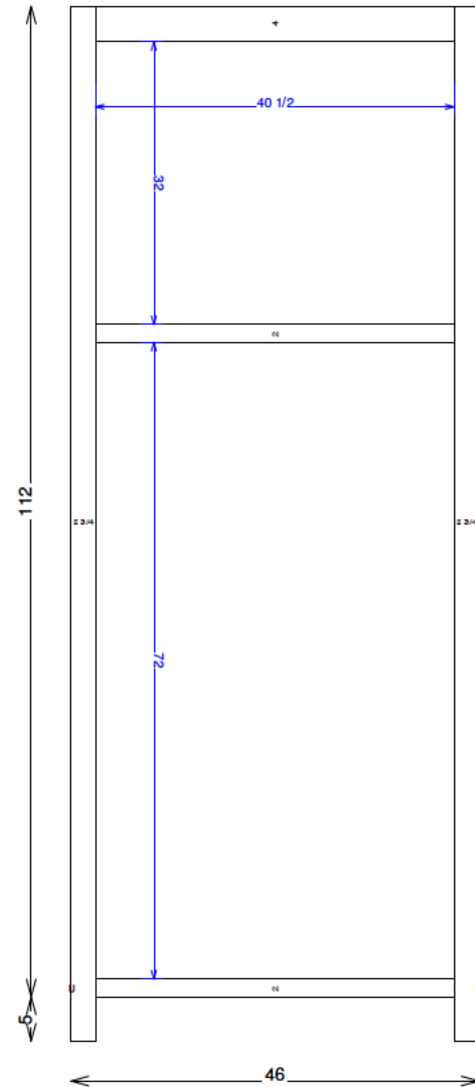

SCRIBE ADDED BOTH SIDES AND BOTTOM

Assembly #600 - Std Tall

CBSI Frame Inset

L. Stile = 2 3/4	L. Scribe = <0>	R. Stile = 2 3/4	R. Scribe = <0>
T. Scribe = 1	B. Scribe = 1 1/4		
Toe Height = 4 1/2	Toe Recess = 3		
Left End = Unfinished	Right End = Unfinished	Back = Unfinished	

MASTER

Room #7 (MASTER VESTIBULE) - Wall #2

Date: _____